

ADAPTER PLATE

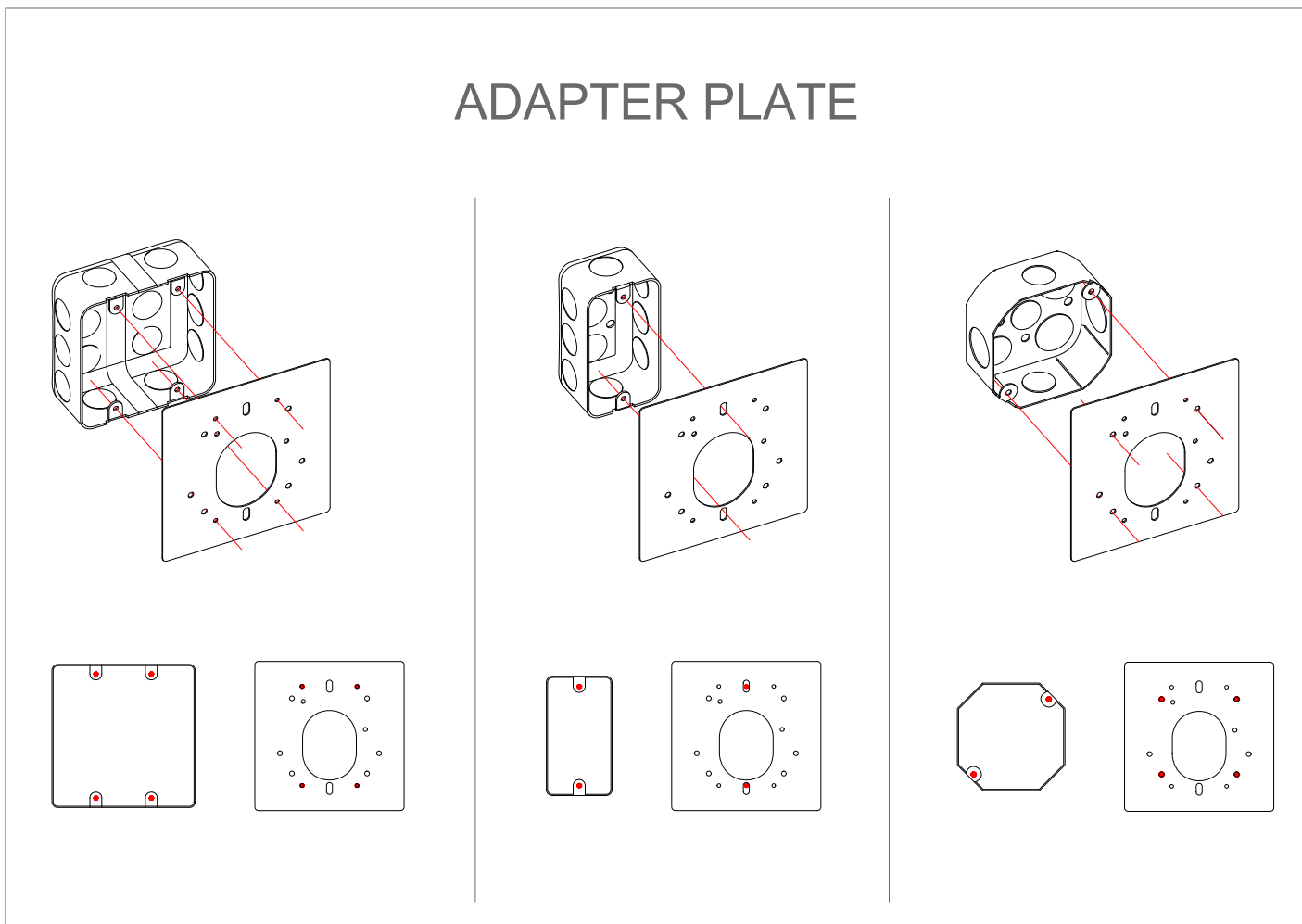

- ① Use the diagram alongside as a reference for the Junction Box.

 Utilizzare lo schema affianco
 come riferimento per la Junction
 Box.

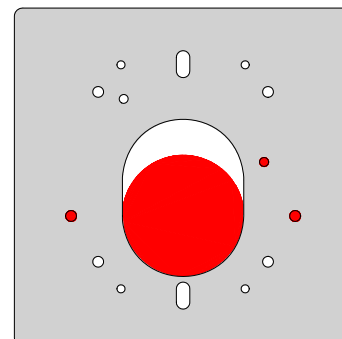
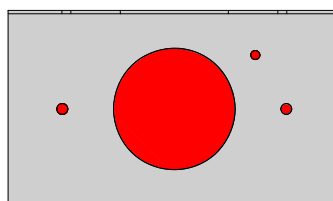

- ② Fix the bracket on the wall
(use appropriate anchors
depending on the type of wall)

Fissare la staffa alla parete
(utilizzare tasselli appropriati
in base al tipo di parete).

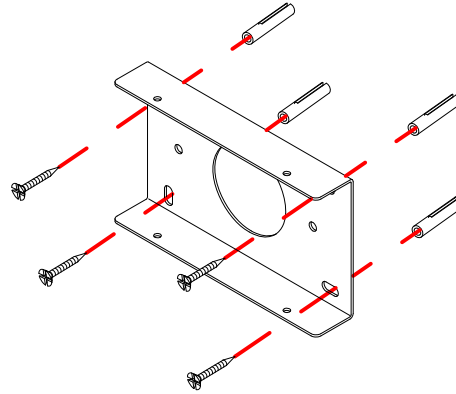

- ③ Connect the wires cables following the sketch.

Connettere i cavi della corrente seguendo lo schema.

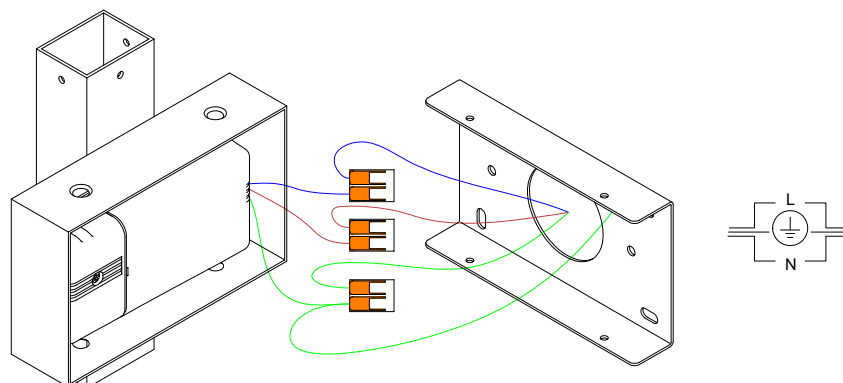

- ④ Fix the lamp to the bracket using
the screws provided.

Fissare la lampada alla staffa a
parete utilizzando le viti fornite.

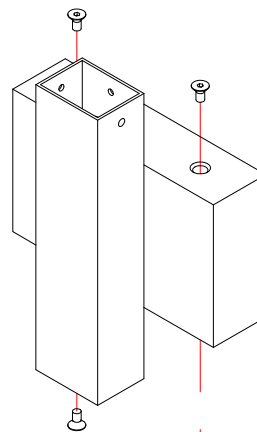



1. KIT



2. Inserire il diffusore di vetro nel suo scompartimento, applicando una leggera pressione sui lati.
Insert the glass diffuser into the proper space, applying a little pressure in the sides.



3. Stringere il grano sul lato sinistro con la chiave fornita.
Screw the grain on the left side with the provided Allen Key.



4. Stringere il grano sul lato destro.
Screw the grain on the right side.



5. Stringere il grano sul lato posteriore.
Screw the grain on the back.



6. Verificare che il vetro sia fissato bene, dopodichè ripetere i cinque passaggi per tutti i vetri.
Check that the glass diffuser is well fastened, then repeat the five steps for all the glasses.

Direct current dimmable electronic drivers with DIP-SWITCH
 Alimentatori elettronici regolabili in corrente continua con DIP-SWITCH

TCI LED **Made in Italy**

0/1...10 V **PUSH** **constant CURRENT** **constant VOLTAGE**

IS 15885 (Part 2 / Sec 13) UL-CLASS2 (2)

RIPPLE FREE **2kV DIFF. 4kV COMM.** **ACTIVE PFC** **DIP-SWITCH** **COOKER HOOD** **SAFETY PROTECTIONS**

EL SELV 60V



IP 20 **SCREW FIXING** **Ø55 2,17"** **Weight - Peso gr. 108 / 3,8 oz.**
Pcs - Pezzi 50

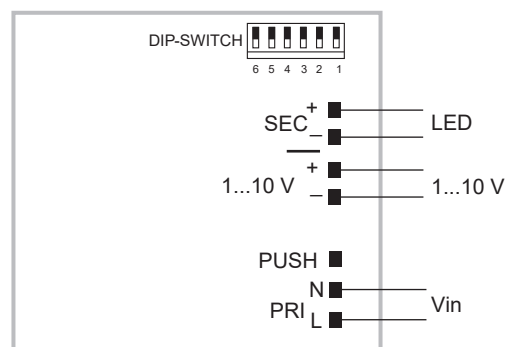
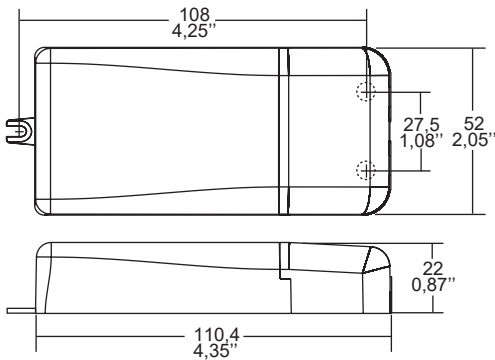

Wiring diagram - Schema di collegamento

1...10 V diagram - Collegamento 1...10 V